

	500 kg trifase	400 kg monofase	EHM
👤	+400 kg	+300 kg	EHPM
👥	+300 kg	+200 kg	
👥👥	+200 kg	+100 kg	
👥👥👥	+100 kg	+0 kg	
👥👥👥👥	+0 kg	/	

PIATTAFORMA DI TRASPORTO / MONTACARICHI
TRANSPORT PLATFORM / MATERIAL HOIST

Dati tecnici	Technical Data	Données Techniques	Datos Tecnicos	EHPM / EHM 400 monofase	EHPM 500 trifase	EHM 500 trifase
Capacità di carico	Capacity	Charge Nominale	Capacidad de carga	400 kg	500 kg	500 kg
Velocità di sollevamento	Lifting speed	Vitesse de lévage	Velocidad de elevación	12 m/min	12 m/min	20 m/min
Massima altezza ancorata	Max anchored height	Hauter max avec ancrages	Altura max con anclajes	120 m	120 m	120 m
Dimensioni interne cesta	Platform dimensions	Dimensions du plancher	Dimensiones de cabina	1,58 x 1,34 m	1,58 x 1,34 m	1,58 x 1,34 m
Tensione alimentazione	Input power range	Tension d'alimentation	Tensión de red	220/230 V 50/60 Hz	380/415 V 50/60 Hz	380/415 V 50/60 Hz
Interruttore protezione linea	Protection switch	Interrupteur de protection	Interruptor de protección	16 A	16 A	16 A
Potenza servizio continuo	Power of the motors	Puissance des moteurs	Potencia de motorreductores	1 x 2,2 kW	1 x 2,2 kW	1 x 3 kW
Corrente di spunto	Starting current	Ampérage au démarrage	Intensidad de arranque	108 A	45 A	56 A
Minima potenza di linea consigliata	Minimum line power suggested	Min. puissance de ligne conseillée	Min. potencia de linea	3 kW	4,5 kW	4,5 kW

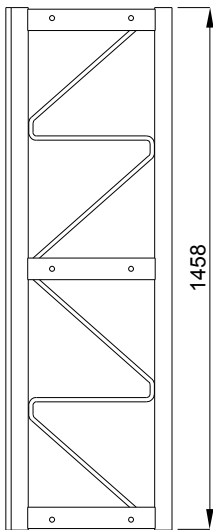

Compatibile con:
Interchangeability.

- EHM 400mini
- EHM 800mini
- EHM 1000mini
- EHM 700
- EHPM 400mini
- EHPM 800mini
- EHPM 1000mini
- EHPM 700

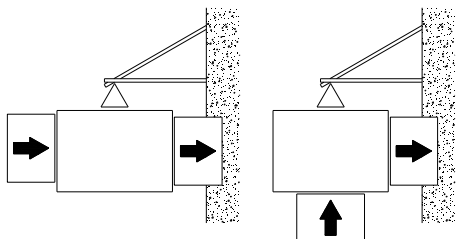
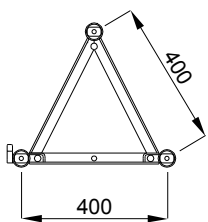

Configurazioni d'accesso possibili
Possible access configurations

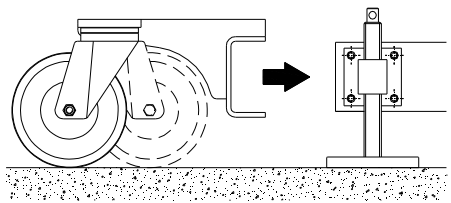

Kit ruote pivotanti
per movimentazione a terra
Rotating wheel kit
for quick positioning

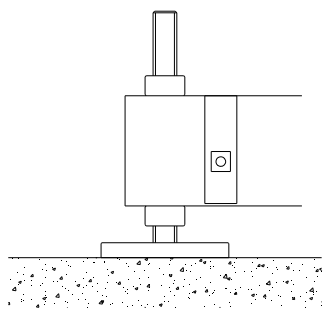

Quattro vitoni di livellamento
Four levelling screw-jacks

